

A4 All Welding 6mm Fillet Welds minimum.
ALL HOLES Ø22 UNLESS NOTED OTHERWISE

DO NOT ASSUME, IF IN DOUBT, ASK

Tolerances: Fabricated Structures +/- 2 mm u.n.o.
: Machined Items +/- 0.05 mm u.n.o.

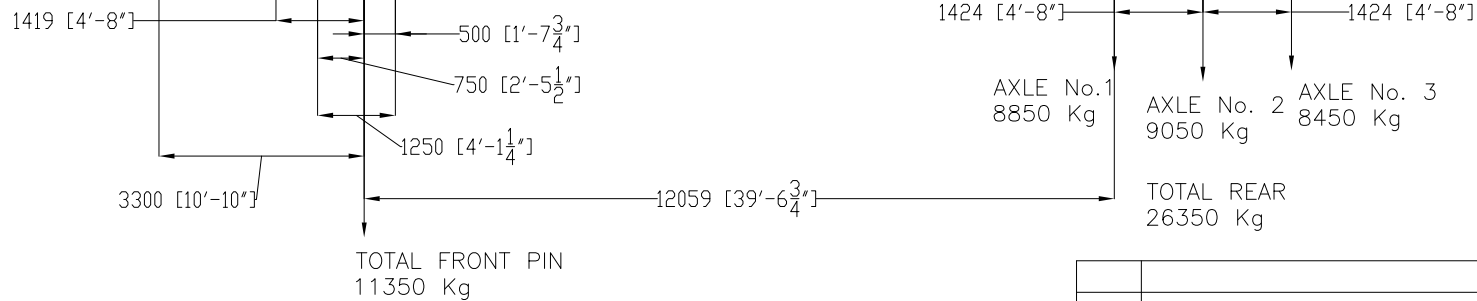
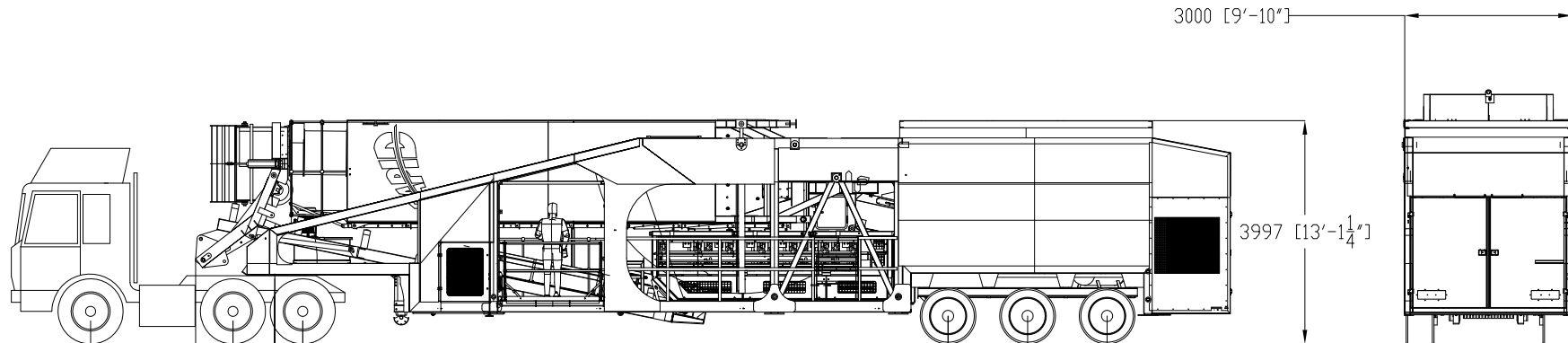
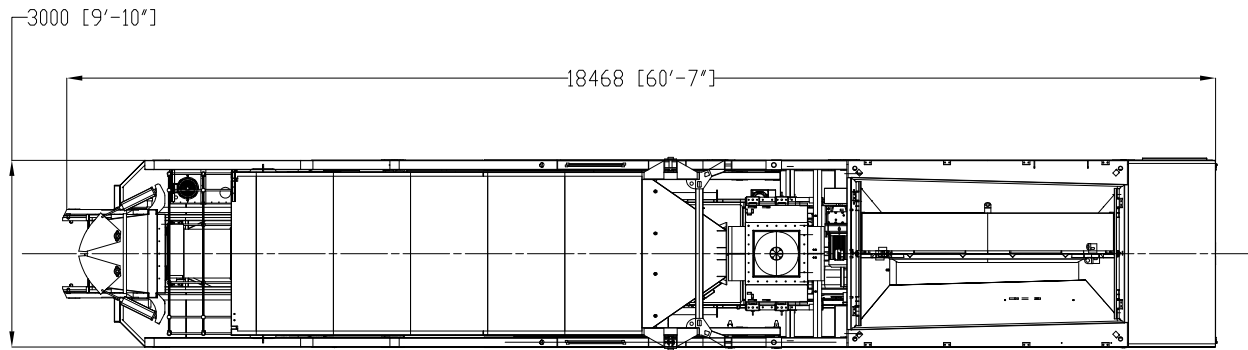

	LOADS CHANGED AS MEASURED	28/03/17	DW	xxxx
REV	DESCRIPTION	DATE	DRAWN	CHECKED

All fabrications to have lifting lugs fitted before painting.
See Production Management.
All conveyor nip points to be guarded.
Fit head drum adjusters to conveyors 5m ctrs or greater



INTERNATIONAL LTD ©

CLIENT:	RAPIDMIX 400CW		
TITLE:	TRANSPORT DETAILS OF RAPIDMIX 400		
DRAWN :	DW	DATE: 13/12/11	CHKED : DATE:
SCALE 1:125	Drawing No:	D-415-A1	- A4